

PIN VISES

93 T-HANDLE TAP WRENCHES

The 93 T-Handle Tap Wrenches are for holding taps, drills, reamers and other small tools to be turned by hand. They are properly heat treated to withstand ordinary shop use. The jaws conform to the tool being held, making it rigid and less apt to loosen.

The 93D, E and F sizes are identical in construction to the 93A, B and C models, except that the bodies are proportionately longer. These longer tap wrenches are very handy in machine, automobile service and aviation repair shops because they eliminate the need for stocking special long taps for depths which cannot be reached with shorter wrenches.

FEATURES

- Sliding handle is frictionally held, permitting the handle to be removed or positioned

NOTE: These tools are designed to hold square shanks. Round shanks can be gripped, but care must be used. Excessive tightening may break the binding nut.

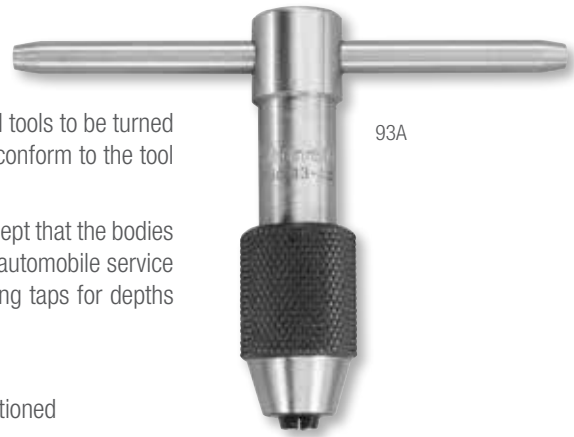

93A

93 T-Handle Tap Wrenches							
Cat. No.	EDP	Capacity Tap Size		Square Shank		Body Length	
		in	mm	in	mm	in	mm
93A	50427	1/16-3/16	1.6-4.7	1/16-5/32	1.6-4	2	50
93B	50428	7/32-7/16	5.5-11	5/32-1/4	4-6.4	2-1/2	65
93C	50429	1/4-1/2	6.4-12.7	3/16-5/16	4.7-8	3-1/2	90
93D	50430	1/16-3/16	1.6-4.7	1/16-5/32	1.6-4	6	150
93E	50431	7/32-7/16	5.5-11	5/32-1/4	4-6.4	10	250
93F	50432	1/4-1/2	6.4-12.7	3/16-5/16	4.7-8	13	330

91 TAP WRENCHES

The 91 Tap Wrenches are strong and well proportioned. They are nicely finished and the gripping surfaces are properly tempered. They will firmly hold square or round shanks. They are plunger operated by knurled sleeve – the spring inside the sleeve causes plunger to back off when pressure is removed.

NOTE: Round shanks can be gripped, but care must be used. Excessive pressure may break the moveable V-jaw.



91A

91 Tap Wrenches							
Cat. No.	EDP	Capacity Tap Size		Square Shank		Body Length	
		in	mm	in	mm	in	mm
91A	50419	1/16-1/4	1.6-6.35	3/32-5/32	2.4-4	6	150
91B	50420	3/16-1/2	4.7-12.7	5/32-9/32	4-7	9	225
91C	50421	1/4-5/8	6.35-16	5/32-3/8	4-9.5	12	300
91D	50422	5/16-3/4	8-19	13/64-7/16	5.2-11	16	400

174 TAP WRENCH

This is a well-designed tap wrench, ideal for holding smaller diameter taps, drills, reamers and other tools up to 1/4" (6.35mm) in diameter.

It will firmly grip round or square shanks. It is lightweight, well proportioned, and the gripping surface is properly heat treated.



174

174 Tap Wrench							
Cat. No.	EDP	Capacity Tap Size		Square Shank		Body Length	
		in	mm	in	mm	in	mm
174	50658	No. 0-14	1/4 diameter	6.35	3-5/8	90	

